

**SUPPLEMENT A13
TO THE AIRPLANE FLIGHT MANUAL**

DA 40 NG

AUTOPILOT SYSTEM

KAP 140

BENDIX/KING

Doc. No. : 6.01.15-E

Date of Issue : 03 Nov 2010

Design Change Advisory : OÄM 40-329

This Supplement to the Airplane Flight Manual is EASA approved under Approval Number 10032543.

0.1 RECORD OF REVISIONS

Rev. No.	Reason	Chapter	Page(s)	Date of Revision	Approval Note	Date of Approval	Date Inserted	Signature
1	MAM 40-447: Reorganization of Chapters according to AFM, Revision 1	all	all	15-Mar-2011	Revision No. 1 of the Supplement Doc. No. 6.01.15-E-A13 is approved under the authority of DOA No. EASA.21J.052			

0.2 LIST OF EFFECTIVE PAGES

Chapter	Page	Date
0	9-A13-0	15 Mar 2011
	9-A13-1	15 Mar 2011
	9-A13-2	15 Mar 2011
	9-A13-3	15 Mar 2011
	9-A13-4	15 Mar 2011
	9-A13-5	15 Mar 2011
1	9-A13-6	15 Mar 2011
2	EASA appr. 9-A13-7	15 Mar 2011
	EASA appr. 9-A13-8	15 Mar 2011
3	9-A13-9	15 Mar 2011
	9-A13-10	15 Mar 2011
	9-A13-11	15 Mar 2011
	9-A13-12	15 Mar 2011

Chapter	Page	Date
4A	9-A13-13	15 Mar 2011
	9-A13-14	15 Mar 2011
	9-A13-15	15 Mar 2011
	9-A13-16	15 Mar 2011
	9-A13-17	15 Mar 2011
	9-A13-18	15 Mar 2011
	9-A13-19	15 Mar 2011
	9-A13-20	15 Mar 2011
	9-A13-21	15 Mar 2011
	9-A13-22	15 Mar 2011
	9-A13-23	15 Mar 2011
	9-A13-24	15 Mar 2011
	9-A13-25	15 Mar 2011
4B	9-A13-26	15 Mar 2011
	9-A13-27	15 Mar 2011
	9-A13-28	15 Mar 2011
	9-A13-29	15 Mar 2011
5, 6	9-A13-30	15 Mar 2011

Chapter	Page	Date
7	9-A13-31	15 Mar 2011
	9-A13-32	15 Mar 2011
	9-A13-33	15 Mar 2011
	9-A13-34	15 Mar 2011
	9-A13-35	15 Mar 2011
	9-A13-36	15 Mar 2011
	9-A13-37	15 Mar 2011
	9-A13-38	15 Mar 2011
	9-A13-39	15 Mar 2011
	9-A13-40	15 Mar 2011
	9-A13-41	15 Mar 2011
	9-A13-42	15 Mar 2011
8	9-A13-43	15 Mar 2011

0.3 TABLE OF CONTENTS

	Page
1. GENERAL	9-A13-6
2. LIMITATIONS	9-A13-7
3. EMERGENCY PROCEDURES	9-A13-9
4A. NORMAL OPERATING PROCEDURES	9-A13-13
4B. ABNORMAL OPERATING PROCEDURES	9-A13-26
5. PERFORMANCE	9-A13-30
6. MASS AND BALANCE	9-A13-30
7. SYSTEM DESCRIPTION	9-A13-31
8. AIRPLANE HANDLING, CARE AND MAINTENANCE	9-A13-43

1. GENERAL

This Supplement supplies the information necessary for the efficient operation of the airplane when the autopilot system KAP 140 is installed. The information contained within this Supplement is to be used in conjunction with the complete AFM.

This Supplement is a permanent part of this AFM and must remain in this AFM at all times when the autopilot system KAP 140 is installed.

2. LIMITATIONS

- A. The entire preflight test procedure outlined under Section 4 of this Supplement, must be successfully completed prior to each flight. Use of the autopilot or manual electrical trim system is prohibited prior to completion of these tests.
- B. During autopilot operation, a pilot with the seat belt fastened must be seated at the left pilot position.
- C. The autopilot must be DISENGAGED during take-off and landing.
- D. The autopilot must not be used if the engine power is set to more than 80 % load indication.
- E. The system is approved for Category I operation only (approach mode selected).
- F. Maximum flap extension during approach operation: T/O position
- G. Autopilot maximum airspeed limitation: 160 KIAS
Autopilot minimum airspeed limitation: 75 KIAS
- H. Altitude select captures below 800 feet AGL are prohibited (if altitude preselect option installed).
- I. The autopilot must be disengaged below 200 feet AGL during approach operations and below 800 feet AGL for all other phases of flight.
- J. Overriding the autopilot to change pitch or roll attitude is prohibited. (Disengage or press CWS while maneuvering.)
- K. The AUTOPILOT circuit breaker must be pulled following any inflight illumination of the red AP TRIM FAIL warning light, but only after first completing the Emergency Procedures (Section 3). The manual electric trim and autopilot autotrim systems will be disabled with the AUTOPILOT circuit breaker pulled.

NOTE

The red AP TRIM FAIL warning will illuminate normally during the preflight self test. If the AP TRIM FAIL light remains illuminated after the preflight self test, the AUTOPILOT circuit breaker must be pulled. The AP TRIM FAIL light will extinguish when the circuit breaker is pulled.

- L. The autopilot must be disengaged if the alternate static valve is open.
- M. The following limitation placard is in the forward view of the pilot:

LIMITATIONS FOR KAP 140 AUTOPILOT SYSTEM:
 ENGINE POWER IS LIMITED TO MAX. 80% LOAD INDICATION DURING AUTOPILOT OPERATION.
 DO NOT USE AP IF "ALTERNATE STATIC" IS OPEN.
 CONDUCT AP AND TRIM CHECK PRIOR TO EACH FLIGHT (SEE AFM).
 AUTOPILOT OFF DURING TAKE-OFF AND LANDING.
 MAXIMUM SPEED FOR AUTOPILOT OPERATION IS 160 KIAS.
 MINIMUM SPEED FOR AUTOPILOT OPERATION IS 75 KIAS.
MINIMUM ALTITUDE FOR AUTOPILOT OPERATION:
 CRUISE, CLIMB, DESCENT AND MANEUVERING: 800 FEET AGL
 APPROACH: 200 FEET AGL

- N. If the CDI source is changed when the autopilot is engaged in NAV mode, the autopilot lateral mode will be revert to ROLL ATTITUDE mode and the NAV mode must be manually selected by the pilot.

2.6 WARNING, CAUTION AND STATUS LIGHTS

Warning Alerts (Red)		Meaning / Cause
G1000 installed	White Wire installed	
AP TRIM FAIL	TRIM FAIL	The annunciation is active when the autopilot automatic trim of the KAP 140 is inoperative.

3. EMERGENCY PROCEDURES

The four step procedure listed below should be among the basic airplane emergency procedures that are committed to memory. It is important that the pilot be proficient in accomplishing all four steps without reference to this manual.

In case of autopilot, autopilot trim, or manual electric trim malfunction.

NOTE

Accomplish items 1 and 2 simultaneously!

1. Airplane control stick GRASP FIRMLY and regain airplane control
2. AP DISC switch PRESS and HOLD throughout recovery
3. Trim RETRIM airplane manually as required
4. AUTOPILOT circuit breaker PULL

NOTE

The AVIONIC MASTER switch may be used as an alternate means of removing all power from the autopilot and electric trim system. If necessary perform steps A through C above, then turn the AVIONIC MASTER switch off before locating and pulling the AUTOPILOT circuit breaker. Turn the AVIONIC MASTER switch ON as soon as possible to restore power to all other avionics equipment. Primary attitude, airspeed and altitude instruments will remain operational at all times.

WARNING

Do not attempt to re-engage the autopilot following an autopilot, autotrim, or manual electric trim malfunction until the cause for the malfunction has been corrected.

Maximum altitude losses and maximum absolute attitude changes due to an autopilot malfunction:

Configuration	Alt Loss	Pitch	Roll
Cruise, Climb, Descent	400 ft	25°	50°
Maneuvering	400 ft	25°	35°
Approach	100 ft	15°	20°

NOTES

The following paragraphs are presented to supply additional information for the purpose of providing the pilot with a more complete understanding of the recommended course of action for an emergency situation.

1. An autopilot trim malfunction may be recognized as an uncommanded deviation in the airplane flight path or when there is abnormal control stick or trim wheel motion. In some cases, especially for autopilot trim, there may be little or no airplane motion, yet the red AP TRIM FAIL annunciator may illuminate and an alert tone will sound. The primary concern in reacting to an autopilot or autopilot trim malfunction, or to an automatic disconnect of the autopilot, is in maintaining control of the airplane. Immediately grasp the control stick and press and hold down the AP DISC switch throughout the recovery. Manipulate the controls as required to safely maintain operation of the airplane within all of its operating limitations.

Elevator trim should be used manually as needed to relieve control forces. Finally, locate and pull the AUTOPILOT circuit breaker, to completely disable these systems.

2. A manual electric trim malfunction may be recognized by the illumination of the red AP TRIM FAIL warning light accompanied by an alert tone, or by unusual trim wheel motions with the autopilot mode DISENGAGED without pilot actuation of the manual electric trim switch. As with an autopilot malfunction, the first concern following a manual electric trim malfunction is regaining control of the airplane. Grasp the control stick firmly and press and hold down the AP DISC switch. Locate and pull the AUTOPILOT circuit breaker.

3. Note that the emergency procedure for any malfunction is essentially the same: immediately grasp the control stick and regain airplane control while pressing and holding the AP DISC switch down, and manually retrim the airplane as needed. After these steps have been accomplished secure the autopilot or electric trim system using the proper circuit breaker. As with any other airplane emergency procedure, it is important that the 4 steps of the autopilot/electric trim emergency procedures according to Section 3 of this Supplement are committed to memory.
4. The AVIONIC MASTER switch may be used as required to remove all power from the autopilot and electric trim systems while the circuit breaker is located and pulled. Return the AVIONIC MASTER switch to the ON position as soon as possible. With the AVIONIC MASTER switch off, all flight instruments will remain operational; however, not all communications, navigation, and identification equipment will be operable.
5. The KAP 140 autopilot incorporates a pitch monitor that detects abnormal airplane acceleration in the vertical axis; therefore, if the airplane, for any reason, is moved rapidly in pitch, the autopilot may disconnect automatically.
6. It is important that all portions of the autopilot and electric trim system are preflight tested prior to each flight in accordance with the procedures published herein in order to assure their integrity and continued safe operation during flight.

WARNING

Do not attempt to re-engage the autopilot or to use the manual electric trim system following an autopilot, autotrim or manual electric trim malfunction until the cause for the malfunction has been corrected.

4A. NORMAL OPERATING PROCEDURES

WARNING

The G1000 altitude references (digits and altimeter bug) are included to increase altitude awareness, and are not connected in any way to the KAP 140 autopilot. Altitude alerter and autopilot functions are accomplished with the altitude set function of the KAP 140 autopilot.

CAUTION

The entire preflight test procedure outlined under Section 4A.5.4 - BEFORE TAXIING of this Supplement must be successfully completed prior to each flight. Use of the autopilot or manual electrical trim system is prohibited prior to completion of these tests.

4A.5.4 BEFORE TAXIING

1. POWER APPLICATION AND SELF TEST - A self test is performed upon power application to the computer. This test is a sequence of internal checks that validate proper system operation prior to allowing normal operation. The sequence is indicated by „PFT“ with an increasing number for the sequence steps. Successful completion of self test is identified by all display segments being illuminated (display test) and the disconnect tone sounding.

NOTE

Following the preflight self test, the red P warning on the face of the autopilot may illuminate indicating that the pitch axis cannot be engaged. This condition should be temporary, lasting approximately 30 seconds. The P will extinguish and normal operation will be available.

If power to the autopilot is cycled in flight (i.e., through the autopilot circuit breaker for instance) it is possible that a 5 minute delay may be necessary prior to autopilot engagement to allow the pitch axis accelerometer circuit to stabilize. Engagement prior to stabilization may result in mildly erratic pitch axis behavior.

WARNING

If the AP TRIM FAIL warning light stays on, the autotrim did not pass the preflight test. The autopilot circuit breaker must be pulled. Manual electric trim cannot be used.

CONTINUED

2. MANUAL ELECTRIC TRIM - TEST as follows:

Press the AP DISC switch down and hold while commanding trim. Manual electric trim should not operate either nose up or nose down.
3. AUTOPILOT - ENGAGE by pressing AP button.
4. FLIGHT CONTROLS - MOVE fore, aft, left and right to verify that the autopilot clutches can be overpowered.
5. AP DISC Switch - PRESS. Verify that the autopilot disconnects.
6. TRIM - SET to take-off position manually.
7. AP DISC switch - PRESS.
8. Autopilot altitude alert/preselector operation (if altitude preselect option is installed).
 - a. BARO setting - CHECK.

CAUTION

If the installation does not incorporate automatic baro setting, the baro display will flash until set manually by the pilot. Continue to set manually throughout the flight each time the altimeter baro setting requires adjustment. No further reminders (flashing) will be given.

- b. ALTITUDE SELECT knob (if altitude preselect option is installed) - ROTATE until the desired altitude is displayed.

CONTINUED

NOTE

An altitude alert is annunciated 1000 ft prior to arrival at the selected altitude. After arriving at the selected altitude, a further alert is annunciated if the airplane deviates from the selected altitude by ± 200 ft. The alert is a series of 5 short tones.

END OF CHECKLIST

4A.5.8 CLIMB / 4A.5.11 DESCENT

1. Elevator trim - VERIFY or SET to place the airplane in a trimmed condition prior to autopilot engagement.

NOTE

Engaging the autopilot into a mistrim condition may cause unwanted attitude changes and a AP TRIM FAIL annunciation.

2. Engine power - VERIFY or SET to max. 80 % load indication.
3. AP button - PRESS. Note ROL and VS annunciators on. If no other modes are selected, the autopilot will operate in the ROL and vertical speed hold modes.

WARNING

The pilot in command must continuously monitor the autopilot when it is engaged, and be prepared to disconnect the autopilot and take immediate corrective action - including manual control of the airplane and/or performance of emergency procedures - if autopilot operation is not as expected or if airplane control is not maintained.

During all autopilot coupled operations the pilot in command must use proper autopilot commands and use the appropriate combination of engine power and wing flaps to ensure that the airspeed is maintained between 75 and 160 KIAS, and the airplane does not exceed other basic airplane operating limitations.

CONTINUED

WARNING

When operating at or near the best rate of climb airspeed and using vertical speed hold, it is easy to decelerate to an airspeed on the back side of the power curve where a decrease in airspeed results in a reduced rate of climb. Continued operation on the back side of the power curve in vertical speed hold mode will result in a stall.

When operating at or near the maximum autopilot speed, it may be necessary to reduce power in order to maintain the desired rate of descent and not exceed the maximum autopilot speed.

CAUTION

Avoid abrupt power changes at low indicated airspeeds with the autopilot engaged.

WARNING

Do not help the autopilot or hand-fly the airplane with the autopilot engaged as the autopilot will run the pitch trim to oppose control stick movement. A mistrim of the airplane, with accompanying large elevator control forces, may result if the pilot manipulates the control stick manually while the autopilot is engaged.

4. BARO setting - CHECK if not automatic.

CONTINUED

Doc. No. 6.01.15-E	Rev. 1	15 Mar 2011	Page 9 - A13 - 18
--------------------	--------	-------------	-------------------

5. Using CWS
 - a. CWS button - PRESS and MOVE airplane nose to the desired vertical speed.
 - b. CWS button - RELEASE. Autopilot will command airplane vertical speed up to the limits of ± 2000 ft/min.
6. Using Vertical Trim
 - a. VERTICAL TRIM control - PRESS either the UP or DN button to modify airplane vertical speed within the limits of ± 2000 ft/min.
 - b. VERTICAL TRIM control - RELEASE when desired vertical speed is displayed. The autopilot will command the desired vertical speed.

END OF CHECKLIST

4A.5.9 CRUISE**NOTE**

The airplane's altitude may vary by as much as 120 feet with an airspeed change from 75 KIAS to 140 KIAS in altitude hold in heavy turbulence.

1. Engine power - VERIFY or SET to max. 80 % load indication.
2. ALT mode selector button - PRESS. Note ALT mode annunciator ON. The autopilot will maintain the selected baro corrected altitude.
3. Capture preselected altitudes (if Altitude Preselect Option is installed)
 - a. ALTITUDE SELECT knob - ROTATE until the desired altitude is displayed. Note ARM annunciation occurs automatically upon altitude selection when the autopilot is engaged.
 - b. ALTITUDE SELECT MODE (ARM) button - PUSH to alternately disarm or arm altitude capture.
 - c. Airplane - ESTABLISH vertical speed necessary to intercept the selected altitude.

NOTE

Autopilot tracking performance will be degraded in turbulence. Use of basic 'ROL' mode is recommended during operation in heavy turbulence. It is recommended that the autopilot be disconnected and that the airplane be flown by hand in severe turbulence.

CONTINUED

4. Change altitudes

- a. Using CWS (recommended for altitude changes greater than 100 ft)
 - 1) CWS button - PRESS and fly airplane to desired altitude.
 - 2) CWS button - RELEASE when desired altitude is reached. The autopilot will maintain the desired altitude.
- b. Using Vertical Trim (recommended for altitude changes less than 100 ft)
 - 1) VERTICAL TRIM control - PRESS and HOLD either the UP or DN button. Vertical trim will seek an altitude rate of change of about 500 fpm.
 - 2) VERTICAL TRIM control - Release when the desired altitude is reached. The autopilot will maintain the desired altitude.

NOTE

As an alternative, press either the UP or DN button with a succession of quick momentary presses programming either an increase or decrease in the altitude reference at the rate of 20 feet per button press.

5. Heading changes

- a. Manual heading changes in ROL mode.
 - 1) CWS button - PRESS and MANEUVER airplane to the desired heading.
 - 2) CWS button - RELEASE. Autopilot will attempt to maintain the airplane at a zero turn rate in the ROL mode.

CONTINUED

Doc. No. 6.01.15-E	Rev. 1	15 Mar 2011	Page 9 - A13 - 21
--------------------	--------	-------------	-------------------

NOTE

Airplane heading may change in ROL mode due to turbulence.

b. Heading hold

1) Heading selector knob - SET BUG to desired heading.

2) HDG mode selector button - PRESS. Note HDG mode annunciator ON. Autopilot will automatically turn the airplane to the selected heading.

c. Command turns (heading hold mode ON)

1) Heading selector knob - MOVE BUG to the desired heading. Autopilot will automatically turn the airplane to the new selected heading.

6. NAV coupling

a. Course bearing pointer - SET to desired course.

b. Heading selector knob - SET BUG to provide desired intercept angle and engage HDG mode.

c. NAV mode selector button - PRESS.

1) If the course deviation bar is greater than 2 to 3 dots: the airplane will continue in HDG mode (or ROL if HDG not selected) with NAV ARM annunciated; when the computed capture point is reached HDG will disengage, the ARM annunciator will go out and the selected course will be automatically captured and tracked.

2) If the course deviation bar is less than 2 to 3 dots: the HDG mode will disengage upon selecting NAV mode; the NAV annunciator will illuminate and the capture/track sequence will automatically begin.

END OF CHECKLIST

4A.5.12 APPROACH & LANDING

1. Approach (APR) coupling (to enable glideslope coupling on an ILS, and more precise course tracking on instrument approaches).
 - a. BARO setting - CHECK if not automatic.
 - 1) Course bearing pointer - SET to desired course.
 - 2) Heading selector knob - SET BUG to provide desired intercept angle.
 - 3) APR mode selector button - PRESS.
 - a) If the course deviation bar is greater than 2 to 3 dots: the airplane will continue in HDG mode (or ROL if HDG not selected) with the APR ARM annunciated; when the computed capture point is reached HDG mode will disengage, the ARM annunciator will go out and the selected course will be automatically captured and tracked.
 - b) If the course deviation bar is less than 2 to 3 dots: the HDG mode will disengage upon selecting APR mode; the APR annunciator will illuminate and the capture/track sequence will automatically begin.
- 4) Airspeed - Maintain 90 to 100 KIAS minimum during coupled autopilot approaches (recommended).

CONTINUED

2. BC approach coupling (i.e., reverse localizer) (REV)
 - a. BARO setting - CHECK if not automatic.
 - 1) Course bearing pointer - SET to the ILS front course inbound heading.
 - 2) Heading selector knob - SET BUG to provide desired intercept angle and engage HDG mode.
 - 3) REV mode selector button - PRESS.
 - a) If the course deviation bar is greater than 2 to 3 dots: the airplane will continue in HDG mode (or ROL if HDG not selected) with REV ARM annunciated; when the computed capture point is reached HDG mode will disengage, the ARM annunciator will go out and the selected course will be automatically captured and tracked.
 - b) If the course deviation bar is less than 2 to 3 dots: the HDG mode will disengage upon selecting REV mode; the REV annunciator will illuminate and the capture/track sequence will automatically begin.
3. Glideslope coupling

NOTE

Glideslope coupling is inhibited when operating in NAV or REV modes. Glideslope arm and coupling occurs automatically in the APR mode when tracking a localizer.

- a. APR mode - ENGAGED. Note GS ARM annunciated.
- b. At glideslope centering - note ARM annunciator goes out.

CONTINUED

Doc. No. 6.01.15-E	Rev. 1	15 Mar 2011	Page 9 - A13 - 24
--------------------	--------	-------------	-------------------

NOTE

Autopilot can capture glideslope from above or below the beam.

NOTE

Altitude preselect captures are not recommended on non precision approaches to capture the MDA. Glideslope coupling will preclude a preselect altitude capture on an ILS.

4. Missed approach

- a. AP DISC switch - PRESS to disengage AP.
- b. MISSED APPROACH - EXECUTE.
- c. AP button - After airplane is in trim, PRESS for autopilot operation if desired.

NOTE

If tracking the ILS course outbound as part of the missed approach procedure is desired, use the NAV mode to prevent inadvertent GS coupling.

5. Before landing

- a. AP DISC switch - PRESS to disengage AP.

END OF CHECKLIST

4B. ABNORMAL OPERATING PROCEDURES**4B.8 FAILURES IN THE AUTOPILOT SYSTEM****4B.8.1 FLASHING PT ANNUNCIATOR**

A flashing PT annunciator with an up or down arrow head in the display of the autopilot computer.

A flashing PT auto trim annunciation on the face of the autopilot suggests a failure of the auto trim function to relieve pitch servo loading in a timely manner. This condition should be temporary.

1. FLASHING PT ANNUNCIATION - OBSERVE airplane pitch behavior. If pitch behavior is satisfactory, wait 5 - 10 seconds for the annunciation to stop.
2. If annunciation continues, airplane control sticks - GRASP FIRMLY, press CWS and check for an out of pitch trim condition. Manually retrim as required.
3. CWS button - Release.
4. AUTOPILOT OPERATION - CONTINUE if satisfied that the out of trim indication was temporary. DISCONTINUE if evidence indicates a failure of the auto trim function.

END OF CHECKLIST

4B.8.2 RED P OR RED R

A red P or R on the face of the autopilot computer.

1. A red P is an indication that the pitch axis of the autopilot has been disabled and cannot be engaged. DO NOT ENGAGE INTO A ROLL AXIS ONLY SYSTEM.

NOTE

If the red P lamp was the result of some abnormal accelerations on the airplane, the annunciation should extinguish within approximately one minute and normal use of the autopilot will be re-established.

2. A red R is an indication that the roll axis of the autopilot has been disabled. The autopilot cannot be engaged.

END OF CHECKLIST

4B.8.3 FLASHING BARO SETTING

A flashing baro setting annunciation (if systems with automatic baro setting installed) on the face of the autopilot computer indicates a failure of the communication link between the altimeter and the autopilot. The flashing will be initiated at the time the communication link failure is detected, and each time thereafter that a change to the preselected altitude is made.

1. Flashing baro setting set proper baro setting
manually (or press BARO to
accept the present value)
2. Altitude alert/preselector setting set as desired

END OF CHECKLIST

Doc. No. 6.01.15-E	Rev. 1 15 Mar 2011	Page 9 - A13 - 27
--------------------	-------------------------	-------------------

4B.8.4 FLASHING MODE ANNUNCIATION

A flashing mode annunciation on the face of the autopilot is normally an indication of mode loss.

1. Flashing HDG - Indication of a failed heading valid input. PRESS HDG button to terminate flashing. ROL will be displayed.
2. Flashing NAV, APR, or REV - Usually an indication of a flagged navigation source. PRESS the NAV, APR or REV button to terminate flashing. ROL will be displayed. (Select a valid navigation source.)

NOTE

A flashing NAV, APR or REV annunciation can also be caused by a failed heading valid input.

3. Flashing GS - Indication of a flagged glideslope. (GS will rearm automatically if a valid GS signal is received.)

NOTE

To continue tracking the localizer, observe the appropriate minimums for a non precision approach. (Press ALT twice in rapid succession to terminate the flashing. Control the pitch axis in the default VS mode.)

NOTE

At the onset of mode annunciator flashing, the autopilot has already reverted to a default mode of operation, i.e., ROL and or VS mode. An immediate attempt to re-engage the lost mode may be made if the offending navigation, glideslope or compass flag has cleared.

END OF CHECKLIST

4B.8.5 EFFECTS OF INSTRUMENT LOSSES UPON AUTOPILOT OPERATION:

G1000 System Lost	Effect upon Autopilot Operation
AHRS	No heading input. HDG, NAV and approach modes inoperative.
ADC	No altitude input. Preselect altitude captures and altitude alerting inoperative. Altitude display will be dashed.

5. PERFORMANCE

No change.

6. MASS AND BALANCE

Upon removal or installation of the KAP 140 autopilot system the change of empty mass and corresponding center of gravity of the airplane must be recorded according to Chapter 6 of the Airplane Flight Manual.

6.5 EQUIPMENT LIST AND EQUIPMENT INVENTORY

Airplane Serial No.:		Registration:		Date:	
Description	Type	Part No.	Manufacturer	S/N	inst'd
AUTOPILOT SYSTEM	KAP 140				
Flight computer	KC 140	065-00176-5403	Bendix/King		
Flight computer	KC 140	065-00176-7703	Bendix/King		
Flight computer	KC 140	065-00176-7904	Bendix/King		
Pitch servo	KS 270 C	065-00178-2500	Bendix/King		
Pitch servo mount	KM 275	065-00030-0000	Bendix/King		
Roll servo	KS 271 C	065-00179-0300	Bendix/King		
Roll servo mount	KM 275	065-00030-0000	Bendix/King		
Trim servo	KS 272 C	065-00180-3500	Bendix/King		
Trim servo mount	KM 277	065-00041-0000	Bendix/King		
Configuration module	KCM 100	071-00073-5000	Bendix/King		
Sonalert		SC 628	Mallory		
COMMUNICATION /NAVIGATION					
Turn & Bank indicator	1394T100-(12RZ)		Mid Continent Instr.		
Turn & Bank indicator	1394T100-(12RA)		Mid Continent Instr.		
Turn & Bank indicator	1394T100-(12RB)		Mid Continent Instr.		

7. SYSTEM DESCRIPTION

7.4 INSTRUMENT PANEL

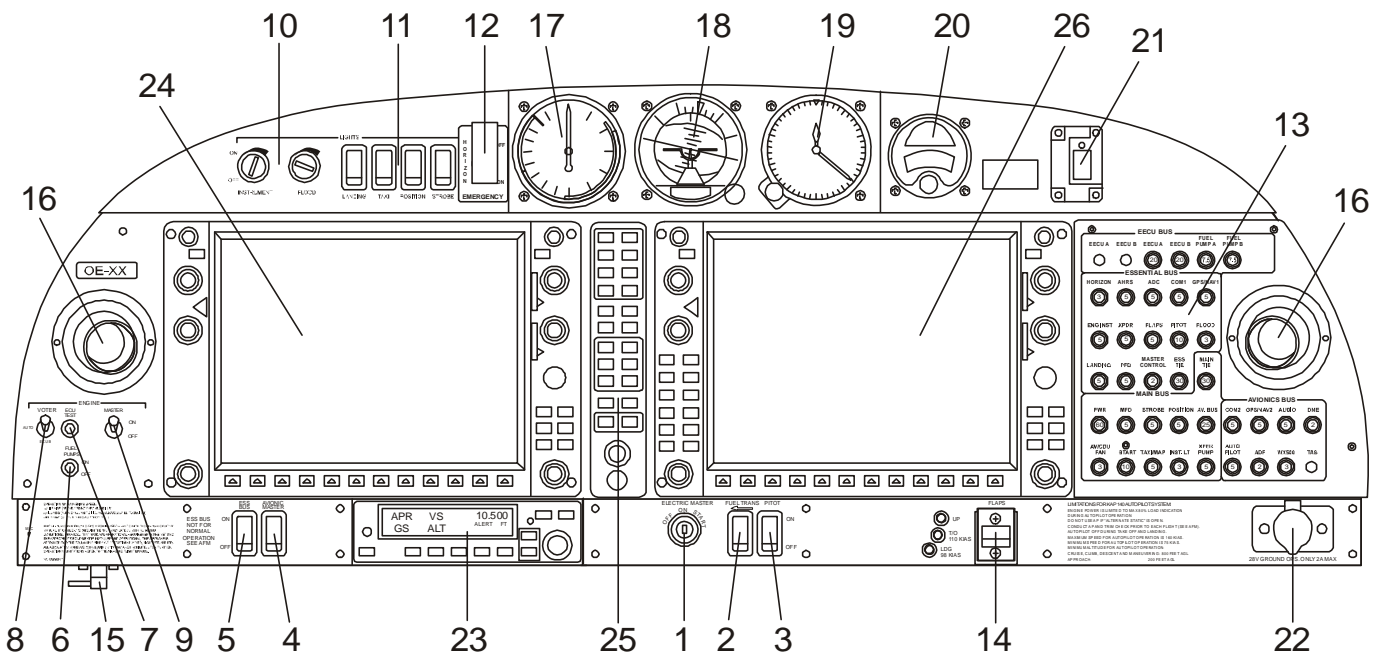

Instrument Panel with G1000 and KAP 140 Autopilot

Major Instruments and Controls	
1 Electric Master key switch	14 Flap selector switch
2 Fuel Transfer switch	15 Alternate static valve
3 Pitot Heat switch	16 Ventilation nozzles
4 Avionics Master switch	17 Backup airspeed indicator
5 Essential Bus switch	18 Backup artificial horizon
6 Fuel pumps switch	19 Backup altimeter
7 ECU Test button	20 Emergency compass
8 ECU Voter switch	21 ELT control unit
9 Engine Master switch	22 Accessory power socket
10 Rotary buttons for instrument lighting and flood light	23 Autopilot control unit
11 Light switches	24 Primary Flight Display (PFD)
12 Emergency switch	25 Audio amplifier / Intercom / Marker beacon receiver
13 Circuit breakers [*]	26 Multi Function Display (MFD)

- *) Designations and abbreviations used to identify the circuit breakers are explained in Section 1.5 - DEFINITIONS AND ABBREVIATIONS of the AFM.

7.10 ELECTRICAL SYSTEM

7.10.3 WARNING, CAUTION AND ADVISORY MESSAGES

Warning Alerts on the G1000

Warning Alerts (Red)		Meaning / Cause
G1000 installed	White Wire installed	
AP TRIM FAIL	TRIM FAIL	The annunciation is active when the autopilot automatic trim is inoperative.

7.13 AVIONICS

This Supplement to the AFM is provided to acquaint the pilot with the limitations as well as normal and emergency operating procedures of the Bendix/King KAP 140 autopilot. The limitations presented are pertinent to the operation of the KAP 140 system as installed in the DA 40 airplane; the autopilot must be operated within the limitations specified herein.

The KAP 140 autopilot has an electric pitch trim system which provides autotrim during autopilot operation and manual electric trim for the pilot when the autopilot is not engaged. The trim system is designed to be fail safe for any single inflight trim malfunction. Trim faults are monitored and annunciated both visually and aurally.

A lockout device prevents autopilot engagement until the system has successfully passed preflight self test. Automatic preflight self test begins with initial power application to the autopilot.

The following conditions will cause the autopilot to automatically disengage:

- A. Power failure.
- B. Internal flight control system failure.
- C. Pitch accelerations in excess of +1.4 g or less than 0.6 g will cause the autopilot clutches to disengage.
- D. Turn coordinator failure.
- E. Autopilot computer monitor that detects either the R (roll) or P (pitch) axis annunciator.

The AVIONIC MASTER switch supplies power to the avionics bus bar of the radio circuit breakers and the autopilot circuit breaker.

The airplane ELECTRIC MASTER key switch function is unchanged and can be used in an emergency to shut off electrical power to all flight control systems while the problem is being isolated.

Activation of AP DISC stick switch will also disconnect the autopilot.

The following circuit breakers are used to protect the following elements of the KAP 140 autopilot:

Label	Function
AUTOPILOT	Supplies power to the KC 140 computer, and the autopilot pitch, roll and pitch trim servos.
MASTER CONTROL	Supplies separate power for autopilot alerting.
AHRS	Supplies power to the AHRS (required for heading input).
ADC	Supplies power to the air data computer (required for altitude input).

SYSTEM CONTROLS AND DISPLAYS

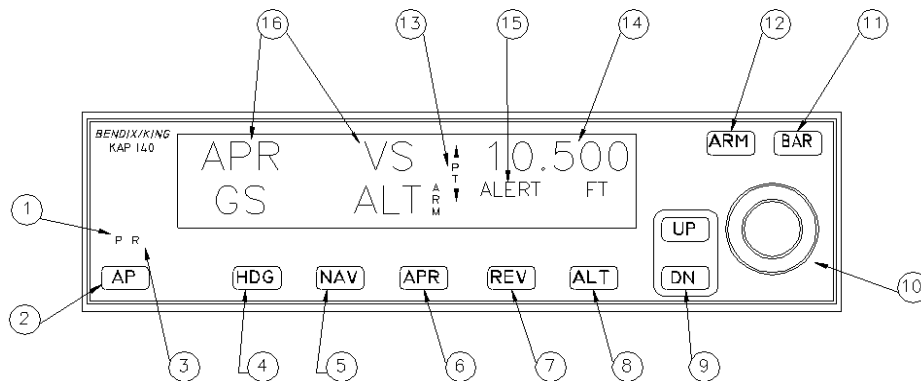

1. PITCH AXIS, (P) ANNUNCIATOR - When illuminated, it indicates failure of the pitch axis and will either disengage the autopilot or does not allow engagement of the pitch axis. The P light may illuminate with the autopilot disengaged. This condition can occur during maneuvering flight when g-thresholds are exceeded. The autopilot monitor will not allow engagement during illumination.
2. AUTOPILOT ENGAGE/DISENGAGE (AP) BUTTON - When pushed, it engages the autopilot if all logic conditions are met. The autopilot will engage in the basic roll (ROL) mode which functions as a wing leveler and in the vertical speed (VS) hold mode. The commanded vertical speed may be displayed manually in the upper right corner of autopilot display area if either UP or DN button is pressed. The captured VS will be the vertical speed present at the moment of AP button press. When pressed again, it will disengage the autopilot. This button is the only button to engage the autopilot.

3. ROLL AXIS (R) ANNUNCIATOR - When illuminated, it indicates failure of the roll axis and will disengage the autopilot or does not allow engagement.
4. HEADING (HDG) MODE SELECTOR BUTTON - When pushed, it will select the heading mode, which commands the airplane to turn to and maintain the heading selected by the heading bug on the HSI. A new heading may be selected at any time and will result in the airplane turning to the new heading. The button can also be used to toggle between HDG and ROL modes.
5. NAVIGATION (NAV) MODE SELECTOR BUTTON - When pushed, will select the navigation mode. The mode provides automatic beam capture and tracking of VOR, LOC or GPS as selected for presentation on the HSI or CDI. NAV mode is recommended for enroute navigation tracking.
6. APPROACH (APR) MODE SELECTOR BUTTON - When pushed, it will select the navigation mode. The mode provides automatic beam capture and tracking of VOR, GPS, LOC, and glideslope (GS) on an ILS, as selected for presentation on the HSI or CDI. APR mode tracking sensitivity is recommended for instrument approaches.
7. BACK COURSE APPROACH (REV) MODE SELECTOR BUTTON - When pushed, it will select the back course approach mode. This mode functions identically to the approach mode except that the autopilot response to LOC signals is reversed.
8. ALTITUDE HOLD (ALT) MODE SELECT BUTTON - When pushed, it will select the altitude hold mode. This mode provides capture and tracking of the selected altitude. The selected altitude is the altitude at the moment the ALT button is pressed. If the ALT button is pressed with an established VS rate present, there will be approximately a 10 % (of VS rate) overshoot, with the airplane returned positively to the selected altitude.

9. VERTICAL TRIM (UP/DN) BUTTONS - The action of these buttons is dependent upon the vertical mode present when pressed. If VS mode is active, the initial button stroke will bring up the commanded vertical speed in the display. Subsequent immediate button strokes will increment the vertical commanded either up or down at the rate of 100 ft/min per button press, or at the rate of approximately 300 ft/min per second if continuously. If ALT mode is active, incremental button strokes will move the altitude hold reference altitude either up or down by 20 feet per press, or if held continuously will command the airplane up or down at the rate of 500 ft/min, synchronizing the altitude hold reference to the actual airplane altitude upon button release. (Note that the altitude hold reference is not displayed. The display will continue to show the altitude alerter reference.)
10. ROTARY KNOBS (only if altitude preselect option is installed) - Used to set the altitude alerter reference altitude; or may be used immediately after pressing the BARO button, to adjust the autopilot baro setting to match that of the airplane's altimeter when manual adjustment is required.
11. BARO SET (BARO) BUTTON (only if altitude preselect option is installed) - When pushed and released, it will change the display from the altitude alerter selected altitude to the baro setting display (either IN HG or HPA) for 3 seconds. If pushed and held for 2 seconds, it will change the baro setting display from IN HG to HPA or vice versa. Once the baro setting display is visible, the rotary knobs may be used to manually adjust the baro setting if the system configuration does not employ automatic correction.

12. ALTITUDE ARM (ARM) BUTTON (only if altitude preselect option is installed) - When pushed it will toggle altitude arming on or off. When ALT ARM is annunciated, the autopilot will capture the altitude alerter displayed altitude (provided the airplane is climbing or descending in VS to the displayed altitude). ALT hold arming when the autopilot is engaged is automatic upon altitude alerter altitude selection via the rotary knobs. Note that the alerter functions are independent of the arming process, thus providing full time alerting, even when the autopilot is disengaged.
13. PITCH TRIM (PT) ANNUNCIATION - Indicates the direction of required pitch trim. With electric trim installed, the annunciation simply provides status to the autopilot request for auto trim. A solid indication represents the lowest demand level for trim, whereas a flashing annunciation implies a greater demand. A solid PT without an arrow head is an indication of a pitch trim fault. Refer to the EMERGENCY PROCEDURES for proper response to a pitch trim fault. During MET operation, this annunciation can be caused by a stuck MET switch. If the stuck switch fault clears, trim operation will resume.
14. ALTITUDE ALERTER/VERTICAL SPEED/BARO SETTING DISPLAY (only if altitude preselect option is installed) - Normally displays the altitude alerter selected altitude.

If the UP or DN button is pushed while in VS hold, the display changes to the command reference for the VS mode in FPM for 3 seconds. If the BARO button is pushed, the display changes to the autopilot baro setting in either IN HG or HPA for 3 seconds.

NOTE

This display may be dashed for up to 3 minutes on start up if a blind encoder is installed which requires a warm up period.

15. ALTITUDE ALERT (ALERT) ANNUNCIATION (only if altitude preselect option is installed) - Illuminates continuously in the region of from 200 to 1000 feet from the selected altitude if the airplane was previously outside of this region.

Flashes

- (1) for two seconds the first time the airplane crossed the selected altitude, and
 - (2) continuously in the 200 to 1000 feet region if the airplane was previously inside of this region (i.e., at the selected altitude). Associated with the visual alerting is an aural alert (5 short tones) which occurs 1000 feet from the selected altitude upon approaching the altitude and 200 feet from the selected altitude on leaving the altitude.
16. PITCH AND ROLL MODE DISPLAYS - Displays the active pitch modes (VS, ALT, ARM, ALT, GS ARM, GS) and roll modes (ROL, HDG, NAV ARM, NAV, APR ARM, APR, REV ARM, REV). Also displayed will be flashing AP annunciation (5 seconds) at each autopilot disconnect accompanied by an aural tone (for 2 seconds).
17. AUTOPILOT DISCONNECT (AP DISC) SWITCH (not shown) - When pressed, it will disengage the autopilot, and interrupt electric trim power. (Located on pilot's and copilot's stick.)
18. MANUAL ELECTRIC TRIM SWITCHES (not shown) - When both switches are pressed in the same direction, they will activate pitch trim in the selected direction. If only one switch is moved, the trim system will not operate. If one switch fail or is moved and held for 3 seconds, the trim monitoring system will detect a switch failure resulting in a PT annunciation on the autopilot display and the disabling of the electric trim system. Autopilot power will have to be cycled to clear the fault. Use of manual electric trim during autopilot operation will disengage the autopilot. (Located on the pilot's stick.)

19. CONTROL WHEEL STEERING (CWS) MODE BUTTON (not shown) - When pressed and held, it disengages the pitch, roll, and pitch trim clutches allowing the pilot to maneuver the airplane by hand. Pressing the CWS button will also sync the autopilot ALT or VS commands to the actual altitude or vertical speed present at the time the button is released. (Located at the pilot's stick.)
20. OMNI BEARING SELECT KNOB - Selects the desired course to be tracked by the autopilot.
21. HEADING SELECT KNOB - Positions the heading bug on the compass card.
22. AP TRIM FAIL ANNUNCIATOR - Illuminates whenever the automated preflight self test detects a pitch trim fault or a continuous monitoring system detects a pitch trim fault in flight. Refer to the EMERGENCY PROCEDURES for proper response to a pitch trim fault.

VOICE MESSAGING

The voice messaging feature provides the pilot with an additional annunciation of normal and abnormal operation of the autopilot system. The voice messages can be heard by the pilot, the co-pilot and the two passengers over the headsets and also over the cabin speaker. The following voice messages may be heard during operation of the autopilot system, where some messages are only available for the altitude preselect flight computers:

- The message 'ALTITUDE' occurs 1000 ft before approaching the selected altitude.
- The message 'LEAVING ALTITUDE' occurs upon a deviation of 200 ft from the selected altitude.
- The message 'AUTOPILOT' occurs when the autopilot has disengaged, either through the pilot, or automatically.
- The message 'CHECK PITCH TRIM' occurs 10 seconds after a continuous flashing of a nose up or nose down trim arrow on the autopilot display panel.
- The message 'AUTOPILOT BARO SET FAIL - SET MANUALLY' is a one time message delivered upon detection of an automatic baro set failure.
- The message 'TRIM IN MOTION, TRIM IN MOTION' occurs when the autotrim has been running for more than 5 seconds, and it repeats until the autotrim stops running.
- The message 'CHECK PITCH TRIM' occurs when the KAP 140 system has detected an out-of-trim condition for more than 15 seconds.

8. AIRPLANE HANDLING, CARE AND MAINTENANCE

No change in Chapter 8.