

## KAP 140 Two Axis with Altitude Preselect Operation

The KAP 140 is a digital, panel-mounted autopilot system for light aircraft.

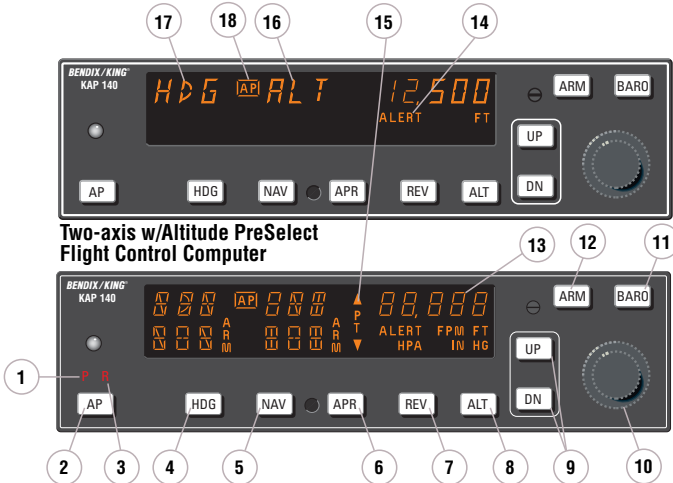

### Full KAP 140 Two-Axis with Altitude Preselect Display

1. **PITCH AXIS (P) ANNUNCIATOR** - When illuminated, indicates failure of the pitch axis and will disengage the autopilot when the failure occurs and not allow engagement of the pitch axis.
2. **AUTOPILOT ENGAGE/DISENGAGE (AP) BUTTON** - When pushed, engages autopilot if all logic conditions are met. The autopilot will engage in the basic roll (ROL) mode which functions as a wing leveler and in the vertical speed (VS) hold mode. The commanded vertical speed is displayed in the upper right corner of autopilot display area for three seconds after engagement or if either the UP or DN button is pressed. The captured VS will be the vertical speed present at the moment of AP button press. When pressed again, will disengage the autopilot. For software version 03/01
3. **ROLL AXIS (R) ANNUNCIATOR** - When illuminated, indicates failure of the roll axis and will disengage the autopilot and not allow engagement.
4. **HEADING (HDG) MODE SELECTOR BUTTON** - When pushed, will arm the Heading mode, which commands the airplane to turn to and maintain the heading selected by the heading bug on either the DG or HSI. A new heading may be selected at any time and will result in the airplane turning to the new heading. Button can also be used to toggle between HDG and ROL modes. This button will engage the autopilot in units with software prior to software version 03/01.

## Two Axis/Altitude Preselect Operations

5. NAVIGATION (**NAV**) MODE SELECTOR BUTTON - When pushed, will arm the navigation mode. The mode provides automatic beam capture and tracking of VOR, LOC or GPS as selected for presentation on the HSI or CDI. NAV mode is recommended for enroute navigation tracking. NAV mode may also be used for front course LOC tracking when GS tracking is not desired.

6. APPROACH (**APR**) MODE SELECTOR BUTTON - When pushed, will arm the Approach mode. This mode provides automatic beam capture and tracking of VOR, GPS, LOC, and Glideslope (GS) on an ILS, as selected for presentation on the HSI or CDI. APR mode is recommended for instrument approaches.

7. BACK COURSE APPROACH (**REV**) MODE SELECTOR BUTTON - When pushed, will arm the Back Course approach mode. This mode functions similarly to the approach mode except that the autopilot response to LOC signals is reversed, and GS is disabled.

8. ALTITUDE HOLD (**ALT**) MODE SELECT BUTTON - When pushed, will select the Altitude Hold mode. This mode provides tracking of the reference altitude. The reference altitude is the altitude at the moment the ALT button is pressed. If the ALT button is pressed with an established VS rate present, there will be altitude overshoot (approximately 10% of the VS rate), with the airplane returned positively to the reference altitude. This button will engage the autopilot in units with software prior to software version 03/01.

9. VERTICAL TRIM (**UP/DN**) BUTTONS - The action of these buttons is dependent upon the vertical mode present when pressed. If VS mode is active, the initial button stroke will bring up the commanded vertical speed in the display. Subsequent immediate button strokes will increment the vertical speed commanded either up or down at the rate of 100 ft/min per button press, or at the rate of approximately 300 ft/min per second if held continuously. If ALT mode is active, incremental button strokes will move the altitude hold reference altitude either up or down at 20 feet per press, or if held continuously will command the airplane up or down at the rate of 500 ft/min, synchronizing the altitude hold reference to the actual airplane altitude upon button release.

*(Note that the altitude hold reference is not displayed. The display will continue to show the altitude alerter reference.)*

10. ROTARY KNOBS - Used to set the altitude alerter reference altitude; or may be used immediately after pressing the BARO button, to adjust the autopilot baro setting to match that of the airplane's altimeter when manual adjustment is required. (In some installations the baro setting is automatically synced to that of the altimeter.)

11. BARO SET (BARO) BUTTON - When pushed and released, will change the display from the altitude alerter selected altitude to the baro setting display (either IN HG or HPA) for 3 seconds. If pushed and held for 2 seconds, will change the baro setting display from IN HG to HPA or

## Two Axis/Altitude Preselect Operations

vice versa. Once the baro setting display is visible the rotary knobs may be used to manually adjust the baro setting if automatic baro correction is not available.

12. **ALTITUDE ARM (ARM) BUTTON** - When pushed will toggle altitude arming on or off. When ALT ARM is annunciated, the autopilot will capture the altitude alerter displayed altitude (provided the aircraft is climbing or descending in VS to the displayed altitude). When the autopilot is engaged, ALT arming is automatic upon altitude alerter altitude selection via the rotary knobs. Note that the alerter functions are independent of the arming process thus providing full time alerting, even when the autopilot is disengaged.

13. **ALTITUDE ALERTER/VERTICAL SPEED/BARO SETTING DISPLAY** - Normally displays the altitude alerter selected altitude. If the UP or DN button is pushed while in VS hold, the display changes to the command reference for the VS mode in FPM for 3 seconds. If the BARO button is pushed, the display changes to the autopilot baro setting in either IN HG or HPA for 3 seconds.

*NOTE: This display may be dashed for up to 3 minutes on start up if a blind encoder is installed which requires a warm up period.*

14. **ALTITUDE ALERT (ALERT) ANNUNCIATION** - The ALERT annunciate is illuminated 1000 ft. prior to the selected altitude, extinguishes 200 ft. prior to the selected altitude and illuminates momentarily when the selected altitude is

reached. Once the selected altitude is reached a flashing ALERT illumination signifies that the 200 ft. "safe band" has been exceeded and will remain illuminated until 1000 ft. from the selected altitude. Associated with the visual alerting is an aural alert (5 short tones) which occurs 1000 feet from the selected altitude upon approaching the altitude and 200 feet from the selected altitude on leaving the altitude.

15. **PITCH TRIM (PT) ANNUNCIATION** - A flashing PT with arrows indicates the direction of required pitch trim. A solid PT without an arrow head is an indication of a pitch trim fault. During manual electric trim operation (autopilot disengaged), detection of a stuck MET switch will be indicated by a solid PT. When the fault is corrected, the annunciation will extinguish.

16. **PITCH MODE DISPLAY** - Displays the active and armed pitch modes (VS, ALT, ARM, ALT and GS).

17. **ROLL MODE DISPLAY** - Displays the active and armed roll modes (ROL, HDG, NAV ARM, NAV, APR ARM, APR, REV ARM, REV, GS ARM). Also displayed will be flashing AP annunciation (5 seconds) at each autopilot disconnect accompanied by an aural tone (for 2 seconds).

18. **AUTOPILOT ENGAGED (AP) ANNUNCIATION** - Illuminates whenever the autopilot is engaged. Flashes during pilot initiated or automatic disengagement. Only applicable for software versions 03/01 or later.

# Two Axis/Altitude Preselect Operations

## System Operating Modes

The lateral modes (HDG, NAV, APR and REV) operate identically as depicted in the KAP 140 Single Axis Operating Modes section. Please refer to that section for text descriptions of lateral mode operation.



### Vertical Speed (VS) Mode

The Vertical Speed (**VS**) mode allows variable speed climbs and descents. The **ALT** button toggles between altitude hold and vertical speed modes.

*Note: The KAP 140 engages into VS mode as a default.*

To operate in the **VS** mode (with autopilot currently disengaged):

1. **AP** button - Press. Note **ROL**, **VS** and current vertical speed is displayed. If no other modes are selected the autopilot will operate in the **ROL** and vertical speed hold modes. For software version 03/01 and later, the **AP** button must be pressed and held for 0.25 seconds to engage the autopilot.
2. **UP** or **DN** button - Select desired climb or descent rate. Each button stroke will increment the vertical speed commanded up or down by 100 ft/min per button press, or at the rate of approximately 300 ft/min per second if held continuously.

To initiate a climb or descent from Altitude Hold (**ALT**) mode:

1. **ALT** button - Press. Note **ALT**

changes to **VS** and current vertical speed is displayed.

2. **UP** or **DN** button - Select desired climb or descent rate. Each button stroke will increment the vertical speed commanded up or down by 100 ft/min per button press, or at the rate of approximately 300 ft/min per second if held continuously.

*Note: VS command value will be displayed during Control Wheel Steering (CWS) and for three seconds following VS engagement or pressing the UP or DN button. Both altitude and vertical speed utilize the same display area. Altitude is always displayed except during vertical speed selection. If the VS command value is not displayed, pressing (and releasing) the UP or DN button will not change the indicated altitude reference but will display the VS command value.*

*Note: When operating at or near the best rate of climb airspeed, at climb power settings, and using vertical speed hold, it is easy to decelerate to an airspeed where continued decreases in airspeed will result in a reduced rate of climb. Continued operation in vertical speed mode can result in a stall.*



### **Altitude Hold (ALT) Mode**

The Altitude Hold (**ALT**) mode maintains the pressure altitude acquired upon selection of altitude hold. The **ALT** button toggles between altitude hold and vertical speed modes.

To operate in the **ALT** mode (with autopilot currently in the Vertical Speed mode):

1. **ALT** button - Press. Note **ALT** is annunciated and autopilot maneuvers to maintain pressure altitude acquired at button selection.
2. **UP** or **DN** button - Select to change altitude. Incremented button strokes will move the reference altitude by 20 feet per press, or if held continuously will command a 500 ft/min altitude change, acquiring a new reference altitude upon button release.

*Note: Incremented altitude changes should be limited to 500 ft. of change.*

# Two Axis/Altitude Preselect Operations

## Altitude Alerting and Preselect

The Altitude Preselect function allows capturing of a desired altitude and transferring into altitude hold. Manual input of desired altitude is accomplished through the rotary knobs on the faceplate of the KAP 140.

The Altitude Alerting function will visually and aurally announce approaching, acquiring and deviation from a selected altitude.

### Altimeter Setting

#### Installations with remote baro input

1. BARO setting - CHECK. depressing the **BARO** button will display the baro setting for three seconds.



#### Installations without remote baro input

Upon successful completion of pre-flight test, the baro display will flash.

1. BARO setting - Enter barometric setting using the rotary knobs OR if correct as displayed, press **BARO**.



*Note: It is recommended that the baro value be updated whenever the aircraft altimeter setting is changed.*

### Baro unit conversion

The barometric pressure display can be toggled between IN HG and HPA as needed by the pilot.

1. **BARO** button - Press and hold for two seconds.



### Altitude Alerter

The function of the Altitude Alerter is independent of the autopilot.

1. ALTITUDE SELECT knob - ROTATE until the desired altitude is displayed.



*Note: The **ALERT** annunciation is illuminated 1000 ft. prior to the selected altitude, extinguishes 200 ft. prior to the selected altitude and illuminates momentarily when the selected altitude is reached. Once the selected altitude is reached, a flashing **ALERT** illumination signifies that the 200 ft. "safe band" has been exceeded and will remain illuminated until 1000 ft. from the selected altitude. Associated with the visual*

alerting is an aural alert (five short tones) which occurs 1000 ft. from the selected altitude upon approaching the altitude and 200 ft. from the selected altitude on leaving the altitude.



### Altitude Preselect

1. ALTITUDE SELECT knob - ROTATE until desired altitude is displayed. ARM annunciation occurs automatically upon altitude selection when the autopilot is engaged.



2. Airplane - ESTABLISH desired vertical speed to intercept the selected altitude.



3. Upon altitude capture, **ALT ARM** will extinguish and **ALT** will be annunciated.

*Note: Altitude preselect captures are not recommended on non-precision approaches to capture the MDA. Glideslope coupling will preclude an altitude capture on an ILS.*



### Voice Messaging

The following standard voice messages will be annunciated as conditions warrant:

1. “**TRIM IN MOTION, TRIM IN MOTION...**” - Pitch trim running for more than 5 seconds.
2. “**CHECK PITCH TRIM**” - An out of trim condition has existed for 15 seconds.
  - a. Airplane Control Wheel - **GRASP FIRMLY**, press **CWS** and check for an out of pitch trim condition. Manually retrim as required.
  - b. **CWS** button - **RELEASE**.
  - c. **AUTOPILOT OPERATION - CONTINUE** if satisfied that the out of trim condition was temporary. **DISCONTINUE** if evidence indicates a failure of the auto trim function.

The following optional voice messages will be annunciated if the system is configured for voice messaging:

1. “**ALTITUDE**” - 1000 feet before approaching selected altitude.
2. “**LEAVING ALTITUDE**” - 200 feet away, departing selected altitude.
3. “**AUTOPILOT**” - Autopilot has disengaged, either through pilot action or automatically.

OPERATIONS WITH THE KAP 140

Takeoff And Climb To Assigned Altitude

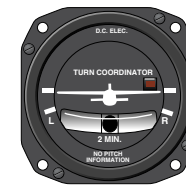
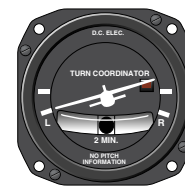
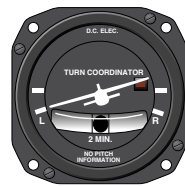
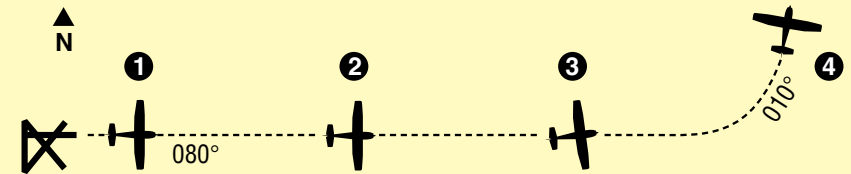
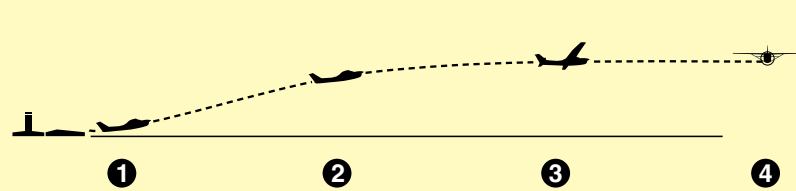

OR



OR



OR



OR



1. The aircraft is well off the ground and established at a safe climb rate.

The heading bug on the DG or HSI is turned to the desired heading of 080° (runway heading). By depressing the **HDG** button on the KAP 140, the autopilot engages into the heading and vertical speed modes and maintains the selected heading of 080° and current rate of climb.

*Note: Press and hold the **AP** button for 0.25 seconds to engage the autopilot (applicable only to software version 03/01 and later).*

2. The heading bug on the DG or HSI is turned to the new desired heading of 010° and the aircraft begins to respond with an immediate left turn. A cruise altitude of 7,000 feet is entered using the rotary knobs. Altitude **ARM** annunciation occurs automatically upon selection.

3. The autopilot is responding to the heading select mode with a left bank. The climb rate has been decreased, using the **DN** button, in preparation for level out. The vertical speed value will be displayed upon selection of the **DN** button and will remain for three seconds.

4. Desired altitude has been reached and automatic altitude capture occurs. The autopilot has completed the turn and is now established on a 010° heading.



GPS Capture Using DG

\* Description of GPS operation based on Bendix/King GPS receiver. Others may require different operation.

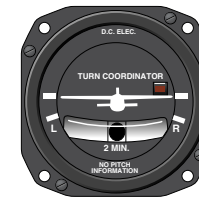
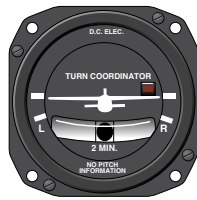
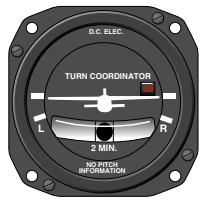
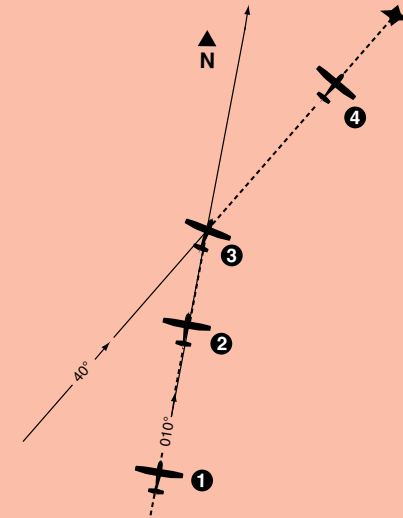

1. Continuing on heading 010°, a GPS waypoint is established. A 30° intercept is desired.

2. The **HDG** button is depressed to select **ROL** mode which will allow an "all angle intercept". GPS data is selected for the CDI and the OBS is set to 040°. The **NAV** button is depressed and **NAV ARM** is annunciated. **ROL** will change to **HDG** and flash for five seconds. **ROL** will then be redisplayed. While the **HDG** annunciation is flashing, move the heading bug to the desired course of 040°. The aircraft will remain wings level until the capture point.

3. When the computed capture point is reached, the **ROL** annunciation changes to **NAV** and a right turn is initiated by the autopilot.

4. The turn is complete and the autopilot is tracking the GPS course.

GPS Capture Using HSI

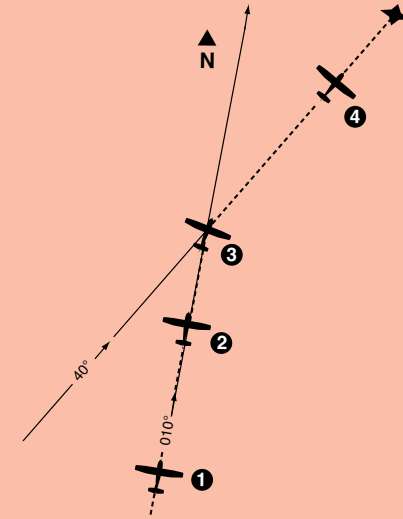

\* Description of GPS operation based on Bendix/King GPS receiver. Others may require different operation.

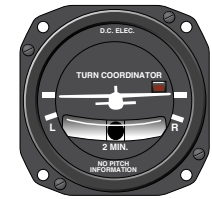
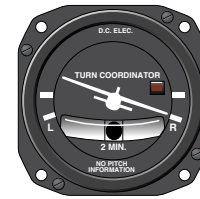
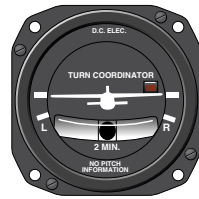

1. Continuing on heading 010°, a GPS waypoint is established. A 30° intercept is desired.

2. GPS data is selected for the HSI. The course pointer is set to 040°. The **NAV** button is depressed and **NAV ARM** is annunciated.

3. When the computed capture point is reached, the **HDG** annunciation changes to **NAV** and a right turn is initiated by the autopilot.

4. The turn is complete and the autopilot is tracking the GPS course.

Outbound On Front Course For Procedure Turn To ILS Approach Using DG

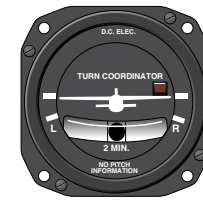
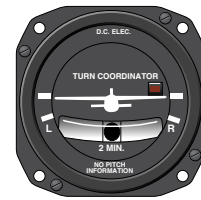
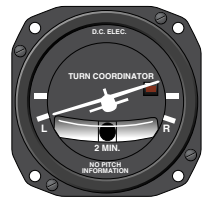
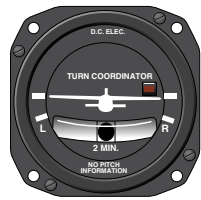
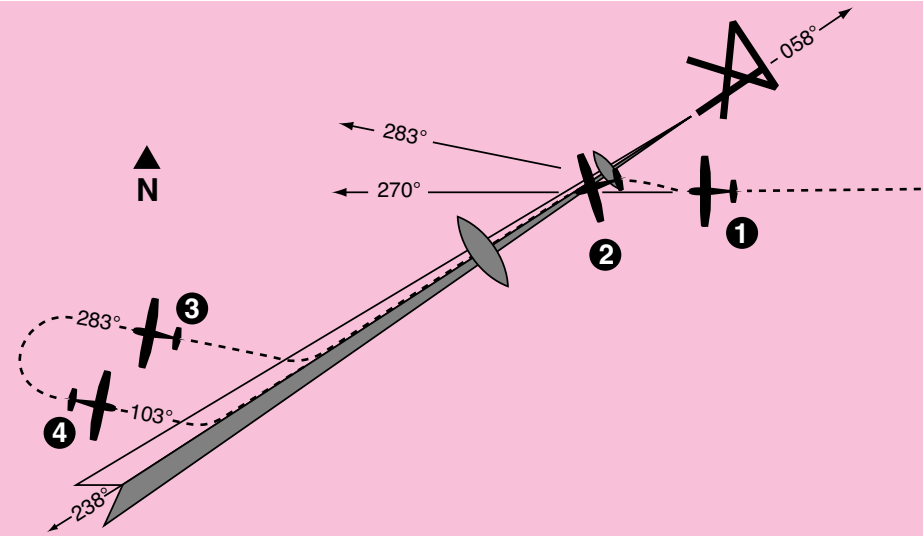

1. The aircraft is heading 270° with heading and altitude hold engaged. To intercept and fly the ILS front course outbound, set the front course on the OBS and depress the reverse course (REV) button. The HDG annunciation will flash for five seconds then extinguish. While the HDG annunciation is flashing, move the heading bug to the front course 058°. Since HDG was active upon selection of REV the autopilot will initiate a 45° intercept to the localizer signal. In this case, the aircraft will turn to 283°.

2. When the computed capture point is reached, auto intercept mode is cancelled and reverse localizer mode is automatically activated and a left turn outbound on the localizer is initiated by the autopilot.

*Note: The left-right deviations of the CDI course deviation needle are reversed (you must turn right to center a deviation of the index to the left). This needle reversing takes place because you are flying outbound on a front course.*

3. At the desired point, HDG mode is used to initiate the procedure turn. Select HDG and set the heading bug to 283°. During the procedure turn outbound, the CDI course index goes off scale to the right. The aircraft is flying away from the localizer centerline at a 45° angle on a selected heading of 283°.

4. Now you have reset the heading bug to 103° and made a 180° turn to this heading. This 103° heading will intercept the front course of 058°. You must now select the approach mode by depressing the APR button on the KAP 140. \* The HDG annunciation will flash for five seconds then extinguish. While the HDG annunciator is flashing, move the heading bug to the front course 058°. Since the 45° intercept is 103°, the aircraft will not turn until the front course is captured.

\* Check the heading displayed on the DG against the magnetic compass and reset if necessary.

Outbound On Front Course For Procedure Turn To ILS Approach Using HSI

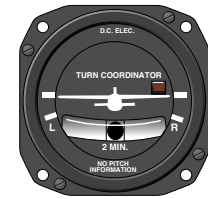
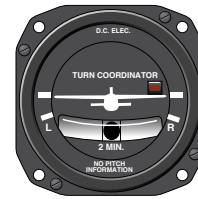
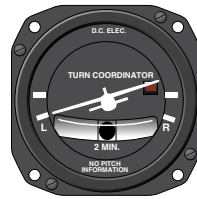
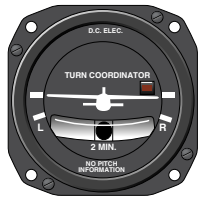
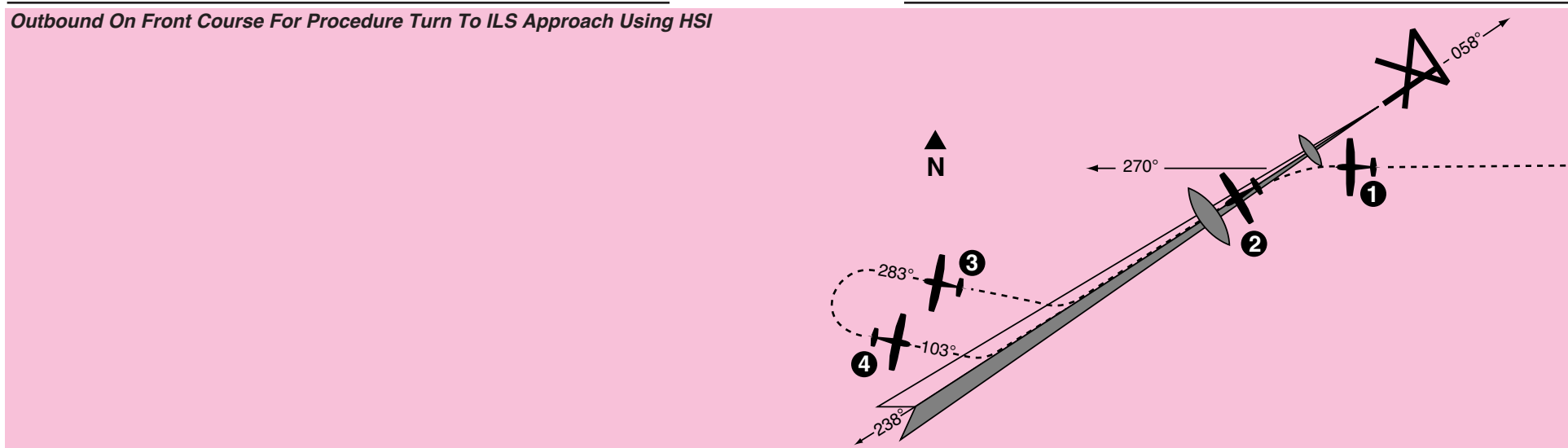

1. The aircraft is heading 270° with heading and altitude hold engaged. To intercept and fly the ILS front course outbound, set the front course on the HSI and depress the back course (**REV**) button. The back course (**REV**) mode is selected to go outbound on the front course. The capture point is now being computed based on closure rate.

2. When the computed capture point is reached, **HDG** mode is cancelled and reverse localizer mode is automatically activated and a left turn outbound on the localizer is initiated by the autopilot.

*Note: The left-right deviations of the HSI course needle operate just as though you were flying a front course approach.*

3. At the desired point, **HDG** mode is used to initiate the procedure turn. During the procedure turn outbound, the deviation bar shows that the aircraft is flying away from the localizer centerline at a 45° angle on a selected heading of 283°.

4. Now you have reset the heading bug to 103° and made a 180° turn to this heading. The 103° heading will intercept the front course of 058°. You must now select the approach mode by depressing the **APR** button on the KAP 140. Automatic capture of the localizer will occur.

Front Course ILS Approach Using DG

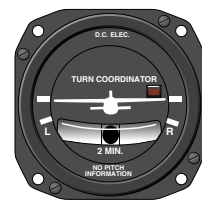
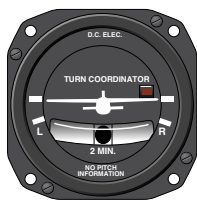
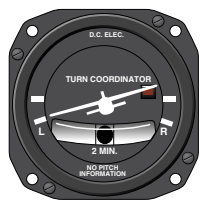
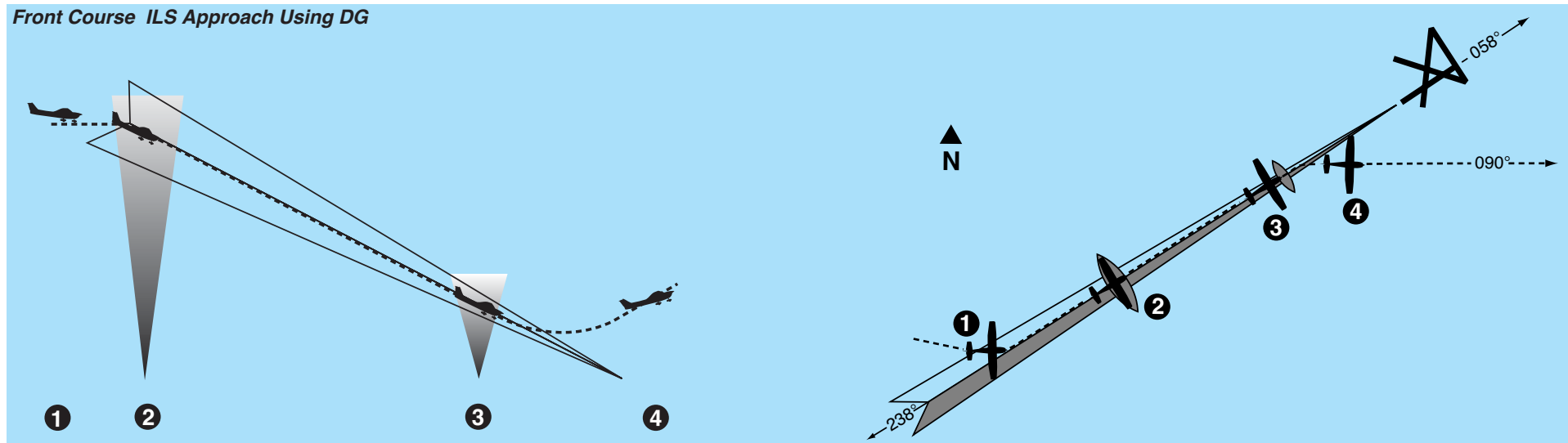

1. Continuing the maneuver on page 96, APR coupling occurs (**HDG** annunciation changes to **APR**), and the glideslope deviation needle is at midscale. Altitude hold is automatically disengaged when the glideslope is captured. The **ALT** annunciator extinguishes and **GS** is displayed. The autopilot will make pitch and bank changes as necessary to maintain localizer and glideslope.

2. The autopilot is following the localizer. At the outer marker, the glideslope deviation needle is at midscale. Altitude hold is automatically disengaged when the glideslope is captured. The **ALT** annunciator extinguishes and **GS** is displayed. The autopilot will make pitch and bank changes as necessary to maintain localizer and glideslope.

3. At the middle marker, the pilot disengages the autopilot with the button on the control wheel. This cancels all operating modes. The flashing **AP** annunciators are displayed and a disconnect tone will sound.

4. The pilot initiates the missed approach and stabilizes the aircraft in the climb. The heading bug is set to the missed approach heading of 090°. By depressing the **HDG** button on the KAP 140, the autopilot engages into the heading and vertical speed modes, commencing a right turn to a heading of 090° and maintaining the rate of climb existing at engagement.

*Note: Press and hold the **AP** button for 0.25 seconds to engage the autopilot (applicable only to software version 03/01 and later).*

Front Course ILS Approach Using HSI

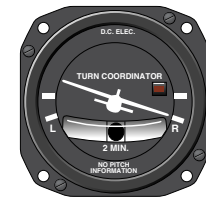
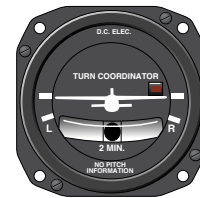
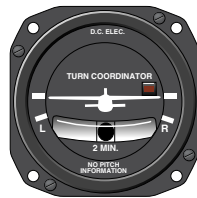
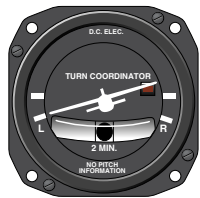
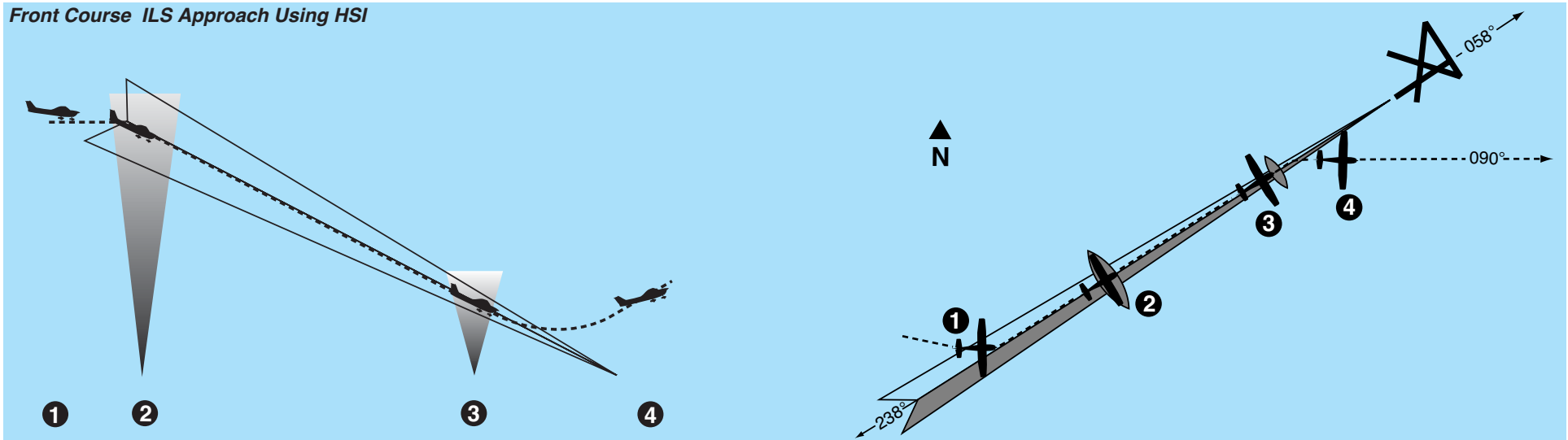

1. Continuing the maneuver on page 98, APR coupling occurs (**HDG** annunciation changes to **APR**), and the glideslope mode is automatically armed. The autopilot will capture the localizer and the CDI course index will center.

2. The autopilot is following the localizer. At the outer marker, the glideslope deviation needle is at midscale. Altitude hold is automatically disengaged when the glideslope is captured. The **ALT** annunciation extinguishes and **GS** is displayed. The autopilot will make pitch and bank changes as necessary to maintain localizer and glideslope.

3. At the middle marker, the pilot disengages the autopilot with the button on the control wheel. This cancels all operating modes. The flashing **AP** annunciations are displayed and a disconnect tone will sound.

4. The pilot initiates the missed approach and stabilizes the aircraft in the climb. The heading bug is set to the missed approach heading of 090°. By depressing the **HDG** button on the KAP 140, the autopilot engages into the heading and vertical speed modes, commencing a right turn to a heading of 090° and maintaining the rate of climb existing at engagement.

*Note: Press and hold the **AP** button for 0.25 seconds to engage the autopilot (applicable only to software version 03/01 and later).*

Outbound on GPS Approach Using DG

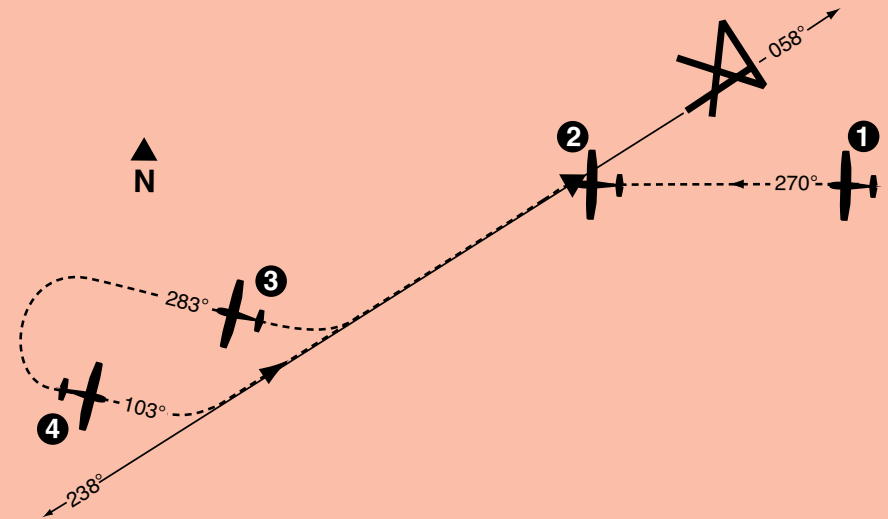

\* Description of GPS operation based on Bendix/King GPS receiver. Others may require different operation.

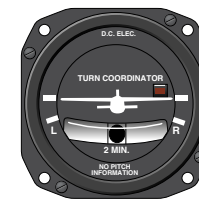
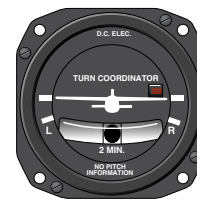
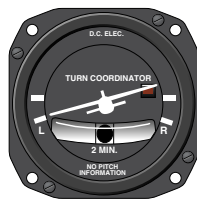
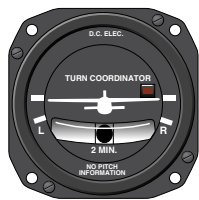

1. The aircraft is in **APR** mode approaching the IAF. Approach arm is indicated on the GPS annunciator.\*

2. Upon waypoint alerting at the IAF, the heading bug is set to 238°, the GPS's Leg/OBS mode switching is set to OBS mode and the OBS is set to 238°. The autopilot initiates a left turn to track the 238° GPS course.

3. At the desired point, heading mode is used to initiate the procedure turn. During the procedure turn outbound, the deviation bar shows that the aircraft is flying away from the GPS course at a 45° angle on a selected heading of 283°.

4. The heading bug has been set to 103° and the aircraft has made a left turn to this heading. The GPS's Leg/OBS mode switching is set to Leg mode and the OBS is set to 058°. Select approach mode by depressing the **APR** button. \*The **HDG** annunciation will flash for five seconds then extinguish. While the **HDG** annunciation is flashing, move the heading bug to 058°. Since the 45° intercept is 103°, the aircraft will not turn until the course is captured.

\* Check the heading displayed on the DG against the magnetic compass and reset if necessary.

Outbound on GPS Approach Using HSI

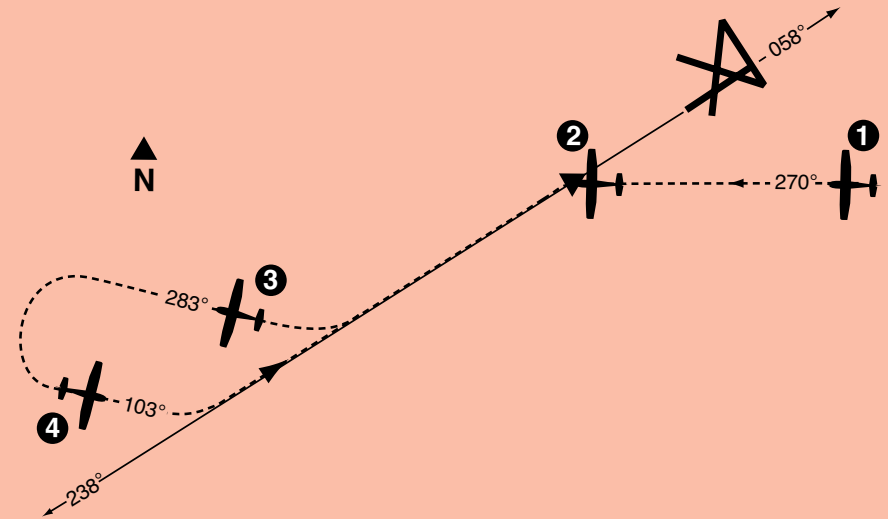

\* Description of GPS operation based on Bendix/King GPS receiver. Others may require different operation.

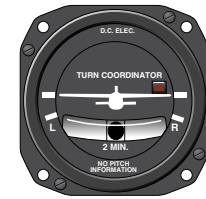
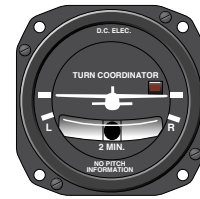
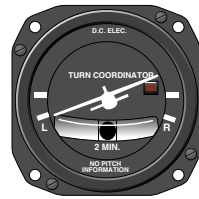

1. The aircraft is in **APR** mode approaching the IAF. Approach arm is indicated on the GPS annunciator.\*

2. Upon waypoint alerting at the IAF, the course pointer is set to 238°, the GPS's Leg/OBS mode switching is set to OBS mode. The autopilot initiates a left turn to track the 238° GPS course.

3. At the desired point, heading mode is used to initiate the procedure turn. During the procedure turn outbound, the deviation bar shows that the aircraft is flying away from the GPS course at a 45° angle on a selected heading of 283°.

4. The heading bug has been set to 103° and the aircraft has made a left turn to this heading. The GPS's Leg/OBS mode switching is set to Leg mode and the course pointer is set to 058°. Select approach mode by depressing the **APR** button.



Inbound on GPS Approach Using DG

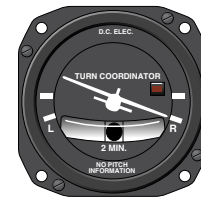
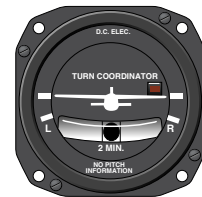
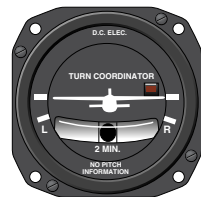
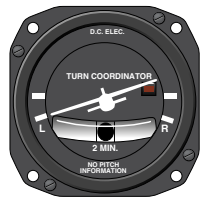
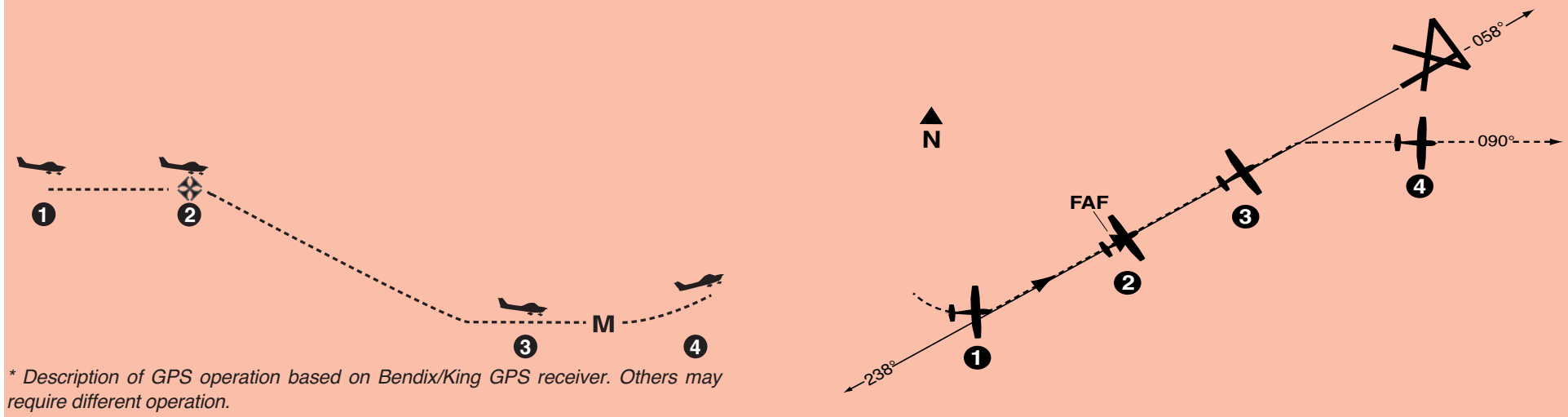

1. Continuing the maneuver on page 104, **APR** mode capture occurs. The autopilot initiates a left turn to track the 058° GPS course.  
\* Approach active is indicated on the GPS annunciator.

2. At the FAF, **ALT** is depressed to activate vertical speed mode. The desired descent rate is obtained using the **DN** button.  
*Remember, speed needs to be controlled with the throttle.*

3. At the MDA, the **ALT** button is depressed causing the autopilot to level off and maintain a constant altitude. At the MAP the pilot disengages the autopilot with the button on the control wheel. A flashing **AP** annunciation is displayed and a distinctive tone will sound.

4. The pilot initiates the missed approach and stabilizes the aircraft in the climb. The heading bug is set to the missed approach heading of 090°. By depressing the **HDG** button on the KAP 140, the autopilot engages into the heading and vertical speed modes, commencing a right turn to a heading of 090° and maintaining the rate of climb existing at engagement.  
*Note: Press and hold the **AP** button for 0.25 seconds to engage the autopilot (applicable only to software version 03/01 and later).*

Inbound on GPS Approach Using HSI

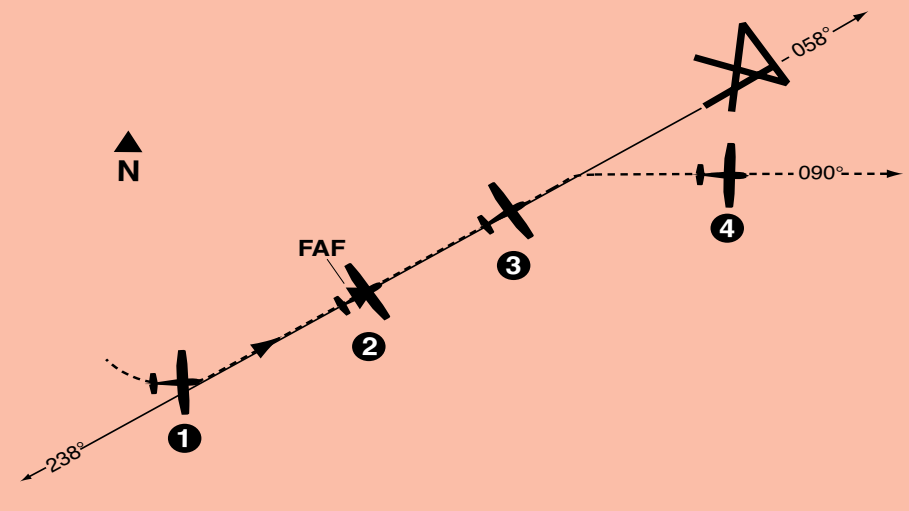
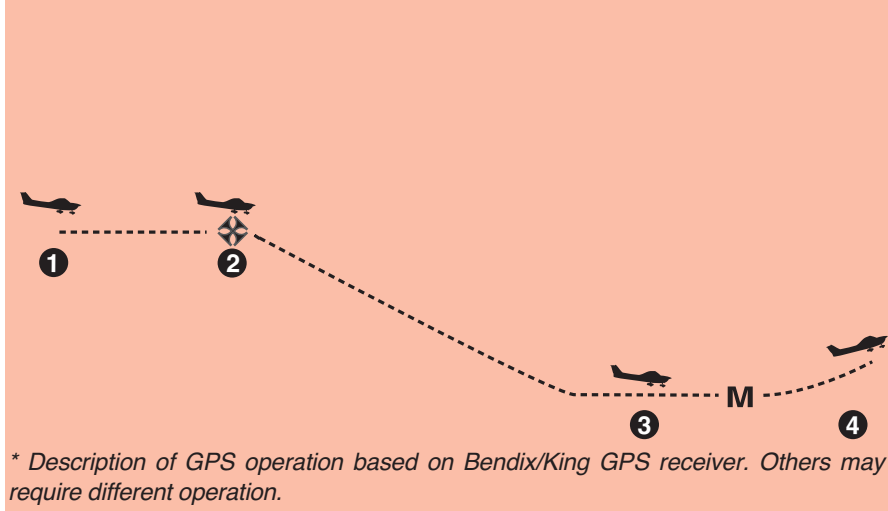

1. Continuing the maneuver on page 106, **APR** mode capture occurs. The autopilot initiates a left turn to track the 058° GPS course. \* Approach active is indicated on the GPS annunciator.



2. At the FAF, **ALT** is depressed to activate vertical speed mode. The desired descent rate is obtained using the **DN** button.  
*Remember, speed needs to be controlled with the throttle.*



3. At the MDA, the **ALT** button is depressed causing the autopilot to level off and maintain a constant altitude. At the MAP the pilot disengages the autopilot with the button on the control wheel. The flashing **AP** annunciators are displayed and a distinctive tone will sound.



4. The pilot initiates the missed approach and stabilizes the aircraft in the climb. The heading bug is set to the missed approach heading of 090°. By depressing the **Hdg** button on the KAP 140, the autopilot engages into the heading and vertical speed modes, commencing a right turn to a heading of 090° and maintaining the rate of climb existing at engagement.  
*Note: Press and hold the **AP** button for 0.25 seconds to engage the autopilot (applicable only to software version 03/01 and later).*

## Two Axis/Altitude Preselect Operations

---

*This page intentionally left blank*